

*MONROY*

AEROSPACE

---

## *ATD-300*

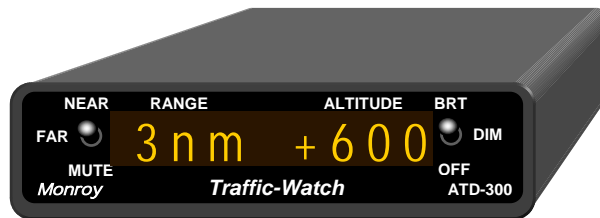

## *Traffic-Watch*

# Operating Manual

No. MA300 Rev. 1.6  
1-2004

*Monroy Aerospace Corp.*

P.O. Box 8217

Coral Springs, Florida 33075 USA

Tel. +1-954-294-9006

[www.monroyaero.com](http://www.monroyaero.com)

Dear Aviation Enthusiast:

Congratulations on the purchase of the ATD-300. We are sure that you will enjoy the benefits of continuous traffic awareness provided by this product that will enhance the safety of your flights. You can be assured that it has been manufactured and tested to high standards and that it will provide many years of trouble free service. At Monroy Aerospace Corp. we strive to provide General Aviation with value added products that will heighten the joy of flying. We welcome your comments on the product and thank you for its selection.

*Jose' J. Monroy*

Jose' J. Monroy  
President

**Table of Contents**

1.0 Description ..... 3

2.0 Setting-up ..... 4

    2.1 Plug & Fly Set-up ..... 5

3.0 Controls and Display ..... 6

4.0 Display Modes ..... 7

5.0 Operation ..... 8

    5.1 Ground Check ..... 8

    5.2 Taxing ..... 8

    5.3 Departure/Approach ..... 8

    5.4 En-route ..... 8

6.0 Operational Notes..... 9

    6.1 High Traffic Activity ..... 9

    6.2 Range Indication ..... 9

    6.3 Spotting Traffic ..... 9

    6.4 IDENT Squawk Altitude..... 9

    6.5 Transponder Code ..... 10

    6.6 Voltage Indication ..... 10

    6.7 Local Altitude Indication Warning ..... 10

7.0 Installation..... 11

    7.1 Location ..... 12

    7.2 In Panel ..... 13

    7.3 Under Panel ..... 14

    7.4 Wiring ..... 15

8.0 Specifications..... 16

9.0 Troubleshooting..... 17

Warranty ..... 18

## 1.0 Description

The ATD-300 *Traffic-Watch* is a passive receiver capable of detecting transponder replies from nearby aircraft and displaying their range and altitude on an 8-character dot matrix yellow LED display. It also provides distinctive voice warnings in relation to traffic proximity. The ATD-300 has a detection range of 5 nautical miles. The system consists of a receiver/indicator unit, antenna, power cord and headphone cable. The receiver is housed in a small aluminum box (2.75" x 0.75" x 5.0") for easy location in the cockpit.

The ATD-300 provides distinctive voice warnings for traffic at different ranges. When set in the FAR mode and traffic is within 3nm and  $\pm 1,000$ ft of vertical separation "*Traffic*" will be annunciated. As the traffic gets closer to about 1nm and within  $\pm 1000$ ft of vertical separation the message will change to "*Traffic Nearby*". When set in the NEAR mode only traffic within 1nm and  $\pm 500$ ft of vertical separation will be annunciated by "*Traffic Nearby*". When set to MUTE there is no warning messages for any traffic, however traffic range and MSL altitude will still be indicated. When there is no traffic activity the ATD-300 will automatically indicate the host transponder MSL pressure altitude. A screwdriver adjustable volume control is located on the bottom side of the unit. Audio output to a speaker (8 ohms) or headphones (300 ohms) is provided on the rear of the unit.

The ATD-300 features a built-in voltage-warning indicator that lets you know if the aircraft supply voltage is out of range. This functions works on the background all the time and is activate after engine start. If an out of range condition exist the ATD-300 annunciates it by voice and by text.

**Note: The ATD-300 will not detect aircraft that do not have an operating transponder. Mode A/C transponders outside a surveillance environment will not produce replies so they will not be detected by the ATD-300. The ATD-300 is not a substitute for continuous traffic surveillance, NOT ALL AIRCRAFT ARE TRANSPONDER EQUIPPED.**

## 2.0 Setting up

The ATD-300 *Plug & Fly* feature allows the owner to operate the unit right away without the need to have it permanently installed in the aircraft. See fig. 1 for set-up

- 1) Connect the provided rubber antenna to the rear BNC connector on the unit. Align the antenna vertically.
- 2) Find a suitable space on top of the glare shield where the ATD-300 is accessible and not blocking the pilot's view and the antenna is not in contact with the windshield or airframe structure.
- 3) Clean well this glare shield location and stick one of the Velcro strips provided. Stick the other strip to the bottom side of the unit. Make sure the strip does not block the VOL adjustment hole.

Note: The ATD-300 can also be located on the overhead panel with the antenna pointing down. However, depending on the surface the Velcro strips may not provide long time support.

- 4) Plug the cigarette lighter power cord to the rear center connector of the unit. Plug the other end to the cigarette lighter jack in the aircraft.
- 5) Plug the headphone cable mini-plug to the rear connector on the unit. Plug the other end 1/4" plug to the aircraft headphone jack. Connect the pilot's headphone to the pigtail phone jack on the cable.

**Note:** If the aircraft is equipped with an intercom system or BOSE ANR headsets connect the 1/4 plug to the emergency headset jack for better results. The pilot's headphones can be connected to their respective phone jacks in the aircraft.

- 6) Turn on the A/C master switch. Set the ATD-300 left switch to NEAR. Turn the unit on (right switch up). After two seconds you should hear "*Traffic Watch On*". Adjust the volume control on the bottom side if it is too high or too low, use a jeweler's screwdriver. Clockwise rotation increases the volume. Repeat the above until desired audio level is achieved
- 7) Affix the ATD-300 to the glare shield. Route the power and headphone cable so they do not interfere with the operation of the aircraft.

Note: During the summer, the ATD-300 may get too hot to the touch if exposed to the sunlight when the aircraft is parked outside. It is recommended that it be covered with a chart or equivalent when parked outside. If the unit gets too hot it may not work properly until it cools down.

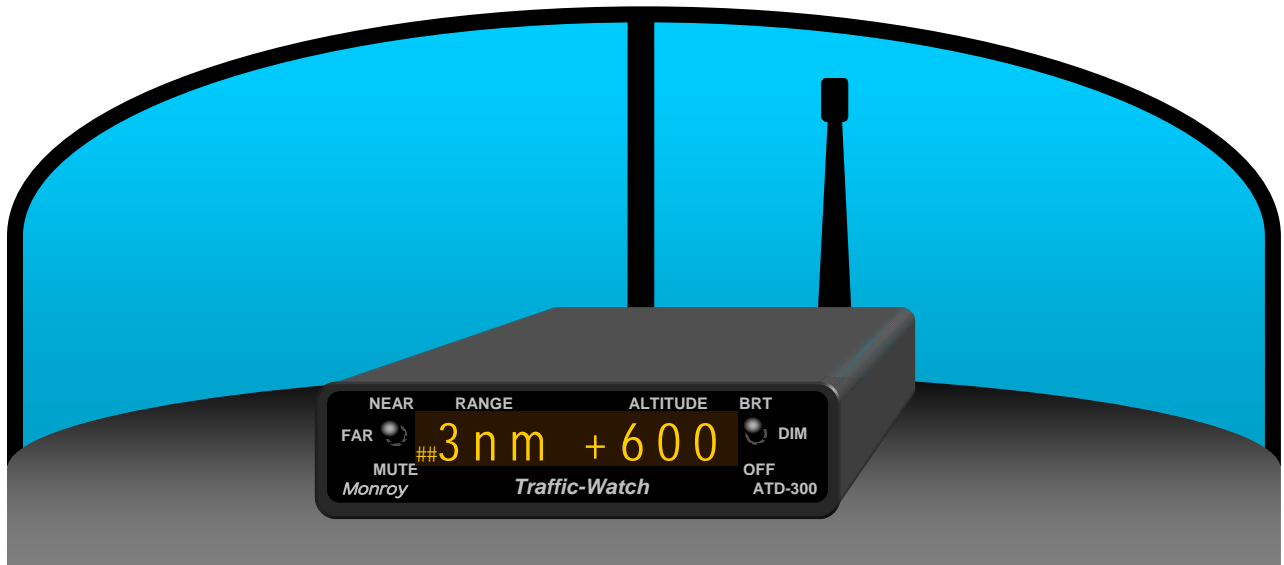

### PLUG & FLY SET-UP

Fig. 1

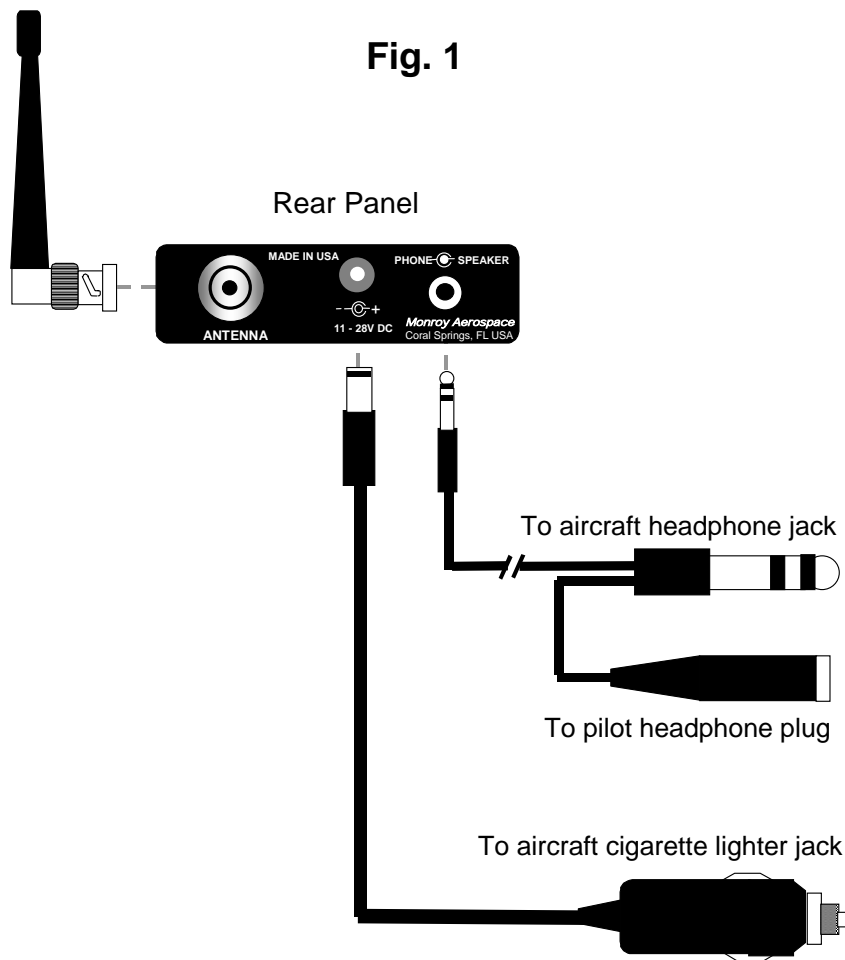

### 3.0 Controls

Operation of the ATD-300 is simple and straightforward. The following describes the control and display functions.



#### BRT Mode

When the right switch is set to the upper position the display is set to its maximum brightness. This mode is normally used during daylight flight.

#### DIM Mode

When the right switch is set to the mid position the display is set to its minimum brightness. This mode is normally used during night flight.

### Traffic Warning Envelope.

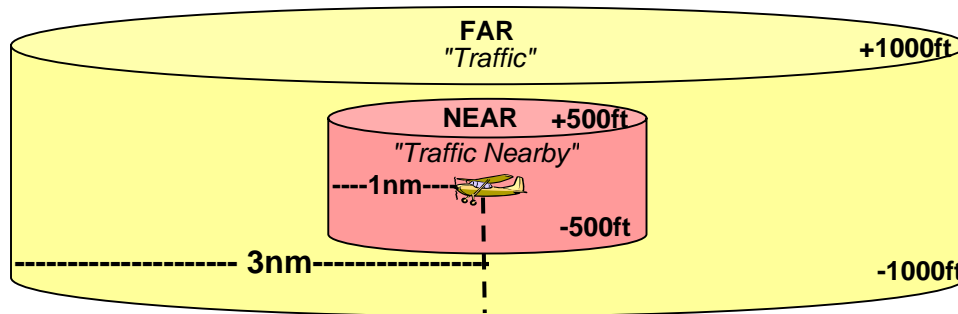

#### FAR Mode

When the left switch is in the mid position (FAR) the traffic voice warnings are initiated whenever traffic is within 3nm and less than  $\pm 1000$ ft of the host aircraft. The female voice will announce: "Traffic". If the traffic or the host is not Mode C equipped the warning will be heard whenever the traffic is within 3nm regardless of the altitude difference. If traffic within 1nm and less than  $\pm 1000$ ft it will announce "Traffic Nearby".

#### NEAR Mode

When the left switch is in the upper position (NEAR) the traffic voice warnings are initiated whenever traffic is within 1nm and less than  $\pm 500$ ft of the host aircraft. The female voice will announce "Traffic Nearby". If the traffic or the host is not Mode C equipped the warning will be heard whenever the traffic is within 1nm regardless of the altitude difference.

#### MUTE Mode

MUTE deactivates all traffic warnings but not the voltage warnings. In the MUTE mode traffic altitude is shown as pressure MSL altitude instead of relative altitude. This can be differentiated on the display by the lack of + or – symbol in front of the altitude number.

### 4.0 Display Modes

The ATD-300 switches automatically to different display modes.

#### Host Altitude: 8,600ft MSL at 29.92"



When there is no traffic indicated the ATD-300 reverts to indicate the onboard transmitted transponder altitude. This is the actual data received by ATC. If there is no Mode C altitude data transmitted the ATD-300 indicates the transponder Mode A code.

#### Traffic Range and Relative Altitude: 5nm at 700ft above.



When there is traffic within 5nm and  $\pm 1000$ ft the ATD-300 will automatically switch to the traffic display mode. If the traffic has no Mode C altitude data the ATD-300 indicates range only.

#### Traffic Range and MSL Altitude: 5nm at 9,300ft MSL



When the left switch is set to MUTE it is possible to see all surrounding traffic within 5nm up to 30,700ft MSL. The ATD-300 will also revert to this display mode when there is no host altitude available. If the traffic has no Mode C altitude data the ATD-300 indicates range only.

#### Low or High Voltage Condition



Whenever there is a low or high voltage condition on the bus the ATD-300 will alert visually and by voice of this condition. This function is activated after engine start and runs on all the time on the background. It has priority over other display modes.

#### Voltage Indication



When there is no host transponder or traffic data the ATD-300 reverts to indicate bus voltage. This is normally shown during power up and taxiing.



## 5.0 Operation

### 5.1 Ground Check

- a) Set the onboard transponder to OFF.
- b) Set the ATD-300 left switch to NEAR. Turn the ATD-300 on. After initialization you should hear the phrase *"Traffic-Watch On"*. The bus voltage should be indicated after this. Note: if your transponder is actively replying or if there is traffic activity in the area the bus voltage may not be indicated.
- c) Set the transponder to ALT and let it warm for one minute. You may see the entered transponder code for a brief period and then the transponder transmitted pressure altitude. Note: There may be about one minute delay after the reply light is blinking due to the transponder altitude encoder warm-up. **If the transponder reply light is not blinking, the transponder is not replying thus no local pressure altitude will be indicated** but instead bus voltage or nearby traffic will be indicated.

Local pressure altitude should be the same as altimeter altitude when set to 29.92". If different, allow up to five minutes for the transponder altitude encoder to stabilize.

### 5.2 Taxing

When taxiing, it is most convenient to set the ATD-300 to MUTE. There maybe traffic on the ground that can cause annoying voice warnings that can distract you from radio communications. Traffic in the area will still be displayed in MSL pressure altitude.

### 5.3 Departure/Approach

- a) Upon departure or approach to the airport traffic area set the left switch to NEAR (up position). This will alert you for traffic within 1nm  $\pm$ 500 feet with the female voice message *"Traffic Nearby"*.
- b) When alerted scan at the horizon instead of looking up or down. Any traffic within  $\pm$ 500 feet will appear close to the horizon line. Small aircraft beyond 1nm are difficult to spot during daytime.
- c) Turn on landing lights to enhance visibility of your own aircraft.

### 5.4 En-route

While en-route you can set ATD-300 to the FAR position for an earlier indication of traffic activity. This will alert you for traffic within 3nm  $\pm$ 1000 feet with the female voice message *"Traffic"*.

**When traffic alerted, do not perform any evasive maneuvers unless visual contact is established.** TCAS II equipment (airlines) may have already indicated an evasive maneuver to the traffic's crew that may be in conflict with your actions. Also differential altimetry errors of up to 300 feet can be encountered between traffic's encoder and the onboard encoder that can show the traffic at opposite altitude.

## **6.0 Operational Notes**

### **6.1 High Traffic Activity**

In areas of high traffic activity the display will show multiple traffics in an alternating fashion. This is most common for traffic between 4 and 5nm. Display preference is given to the closest traffic by distance. As traffic gets closer background traffic display is reduced or eliminated.

### **6.2 Range Indication**

The ATD-300 determines range by traffic signal strength. Unlike radar signal time delay range determination signal strength method is subject to some variables. Among them: traffic transponder power output, altitude difference, relative attitude, antenna location and installation. Because of these variables it is impossible for a passive system to have fractional nm accuracy but rather a range of values. The ATD-300 is calibrated to cope with the above variables and provide you with a range of values rather than an inaccurate distance value. The table below shows the traffic's range of distance values for traffic indicated range.

<u>Indicated Range</u>	<u>Actual Traffic Distance (D)</u>
<b>0nm</b>	100ft<D<1nm
<b>1nm</b>	1nm<D<2nm
<b>2nm</b>	2nm<D<3nm
<b>3nm</b>	3nm<D<4nm
<b>4nm</b>	4nm<D<5nm
<b>5nm</b>	5nm<D

When the ATD-300 is used in the portable configuration the range indication is subject to more variation due to shadowing effects by the cockpit environment. These are mostly eliminated with the use of an external antenna.

### **6.3 Spotting Traffic**

Traffic indicated may not be visible unless at 1nm or closer. This is most common for small aircraft during daylight. If alerted by the message "*Traffic Nearby*" look at the horizon rather than up or down and turn the landing lights on.

### **6.4 IDENT Squawk Altitude**

Although unusual, some ATC rarely assigned transponder codes may cause the ATD-300 to interpret them as altitude (squawk altitude). This may cause the ATD-300 display to alternate between the actual host altitude and the squawk altitude when reading local altitude **ALT**(local altitude). This will not impair the traffic warning ability but you may get warnings for traffic at the squawk altitude. The ATD-300 will display **IDENT** any time there is a squawk altitude conflict. To clear the conflict; push the IDENT button on your transponder. After this the display will indicate the transponder code for 20 seconds and clear the conflict. ATC may have asked you to ident for these codes so you may not see the **IDENT** indication. Some traffic may have a squawk altitude code too, but because of the ATD-300 traffic altitude filtering you will only see the altitude closest to you.

## 6.0 Operational Notes (cont.)

### 6.5 Host Transponder Code Indication

The ATD-300 will indicate the onboard transponder squawk code for 20 seconds whenever the transponder Ident button is depressed. This verifies that the transponder Ident and code functions are working properly. This procedure works best when airborne and within range of a ground ATC radar.

### 6.6 Voltage Indication

To read bus voltage set the following:

1. Set transponder to STBY
2. If there is no traffic in the area the ATD-300 will display bus voltage within 15 sec.
3. Set transponder back to ALT.

If there is an over-voltage or under-voltage condition the ATD-300 will display it immediately and annunciate it regardless of any switches combination. This can be tested by the following procedure:

1. Engine must be running
2. ATD-300 must be on.
3. Pull the alternator/generator field circuit breaker (both engines for twins).
4. After 5 seconds the display will indicate LOW VOLT.
5. After 15 seconds or less voice will annunciate "*Check Voltage*"
6. Push the circuit breaker in and the warnings should go away.

To disable an active voltage warning just turn off and on the unit. The function will not be activated unless normal voltage is established.

#### Voltage Alarm Thresholds

14 Volts systems:    LOW VOLT: below 12.0 Volts    HI VOLT: above 14.8 Volts

28 Volts Systems:    LOW VOLT: below 24.0 Volts    HI VOLT: above 29.6 Volts

The ATD-300 will recognize automatically your voltage system.

### 6.7 Warning: Local Altitude Indication

The ATD-300 decodes and displays the uncorrected pressure altitude data from your transponder when displaying ALT(altitude). The ATD-300 local altitude reading may not be the same as that indicated by the altimeter when the atmospheric pressure is different than 29.92". This is because transponder altitude encoders are calibrated to 29.92". This altitude indication may be as much as 1,000ft different from a corrected altimeter and should not be used for altitude guidance.

## **7.0 Installation**

Because of its compact size the ATD-300 can be located anywhere in the cockpit, figure 2 suggest some locations. See figures 3, 4, 5 and 6 for installation details. The following recommendations will assure good performance.

1. Locate the unit within pilot's view and reach.
2. Keep antenna cable as short as possible, no longer than 10 feet.
3. Keep the ATD-300 antenna no closer than 2 feet from the transponder antenna.
4. If the antenna is installed on a non-metal structure make sure that a 6" x 6" or bigger ground plane is provided. This will also help on supporting the antenna.
5. Antenna should be vertically oriented. Do not use horizontal polarization.
6. Whenever possible install the antenna on the bottom side of the fuselage as forward as possible. If not, top mounted antenna is acceptable.
7. Whenever possible connect ATD-300 audio output to the aircraft audio panel unswitched input as shown on fig. 6.
8. The ATD-300 can be connected to an unused DME antenna already installed.
9. The ATD-300 cannot share the transponder antenna in any way.

## INSTRUMENT PANEL LOCATIONS

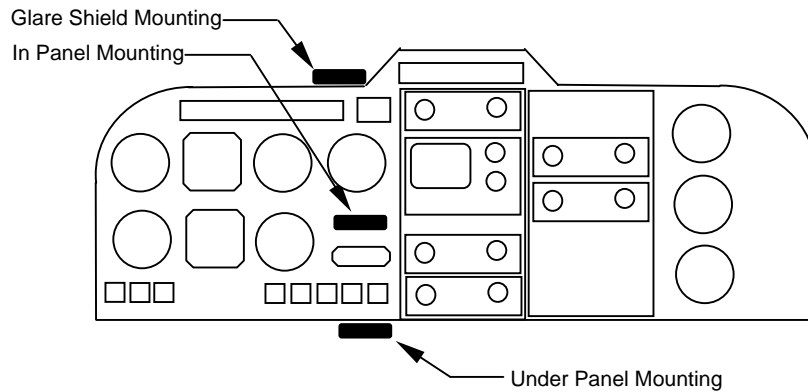
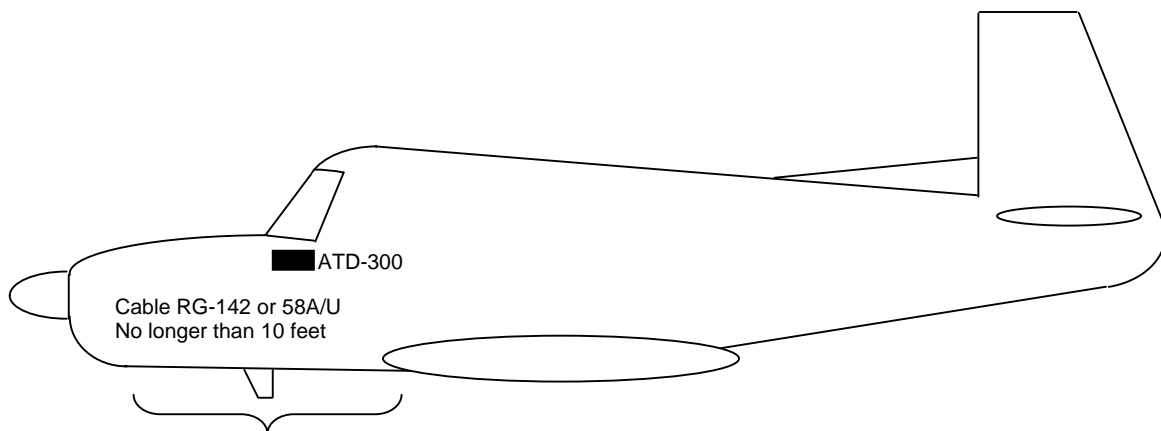

Fig. 2

## ANTENNA LOCATIONS

The antenna location described below will provide good forward coverage. For twins optimum performance location is at the bottom side of the nose section. For wet fuselage amphibian aircraft locate the antenna on top. The antenna should not be closer than 2 feet or farther than 200 feet from a transponder antenna.



Bottom mounted antennas provides best overall performance. For low wing airplanes: best if mounted forward of the wing.

Fig. 3

### IN-PANEL MOUNTING

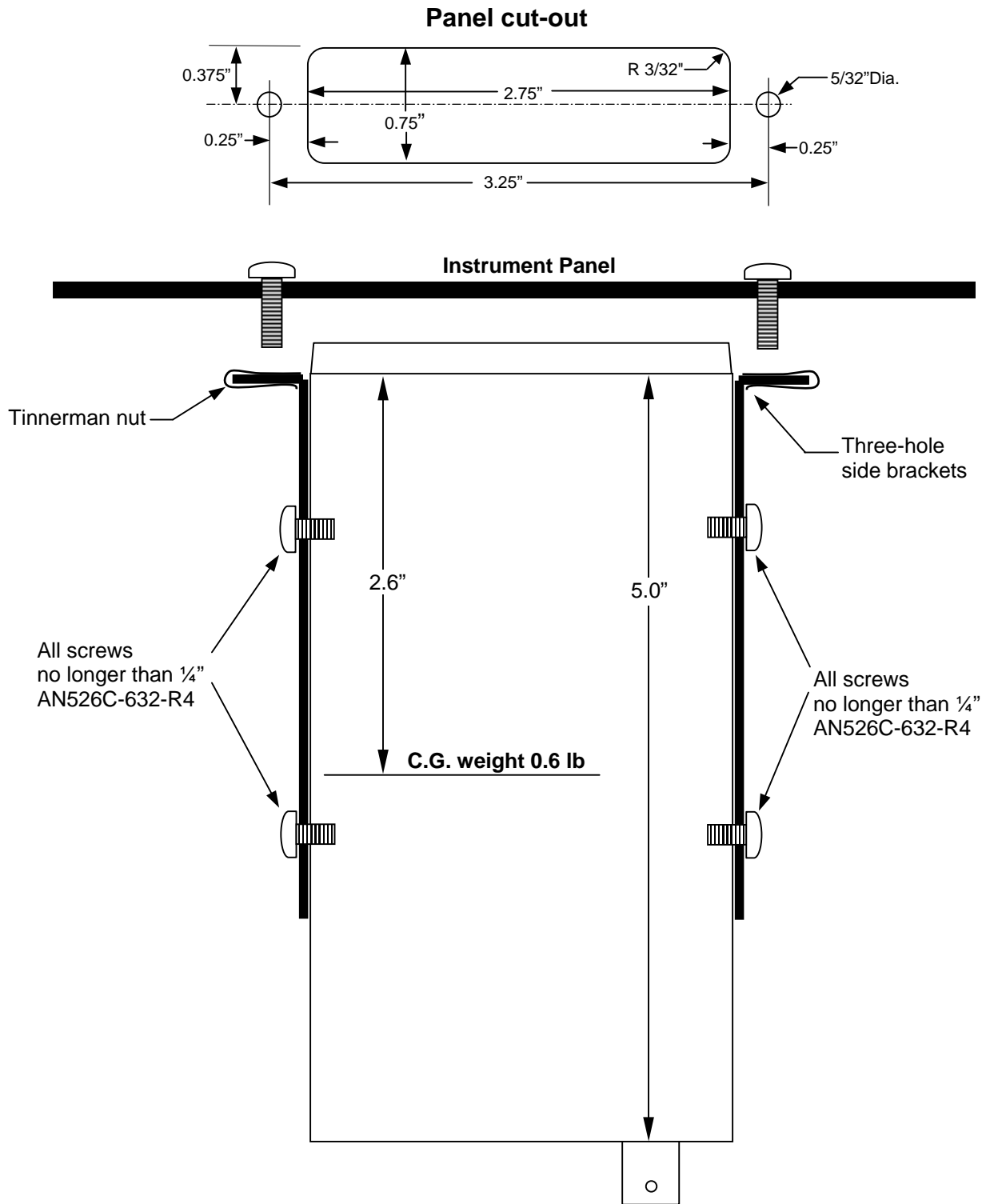

**Fig. 4**

### UNDER PANEL MOUNTING

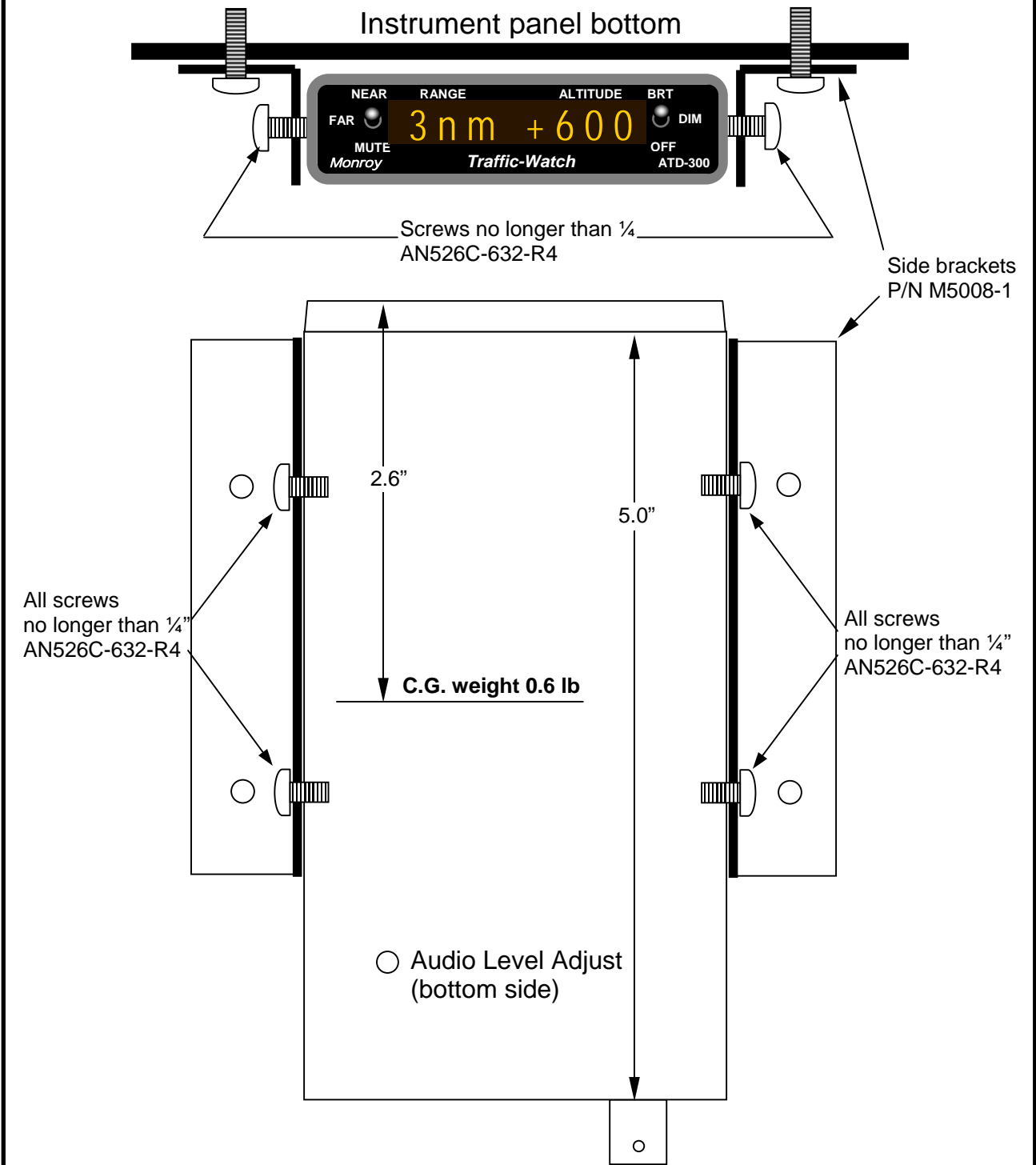

Fig. 5

# WIRING DIAGRAM

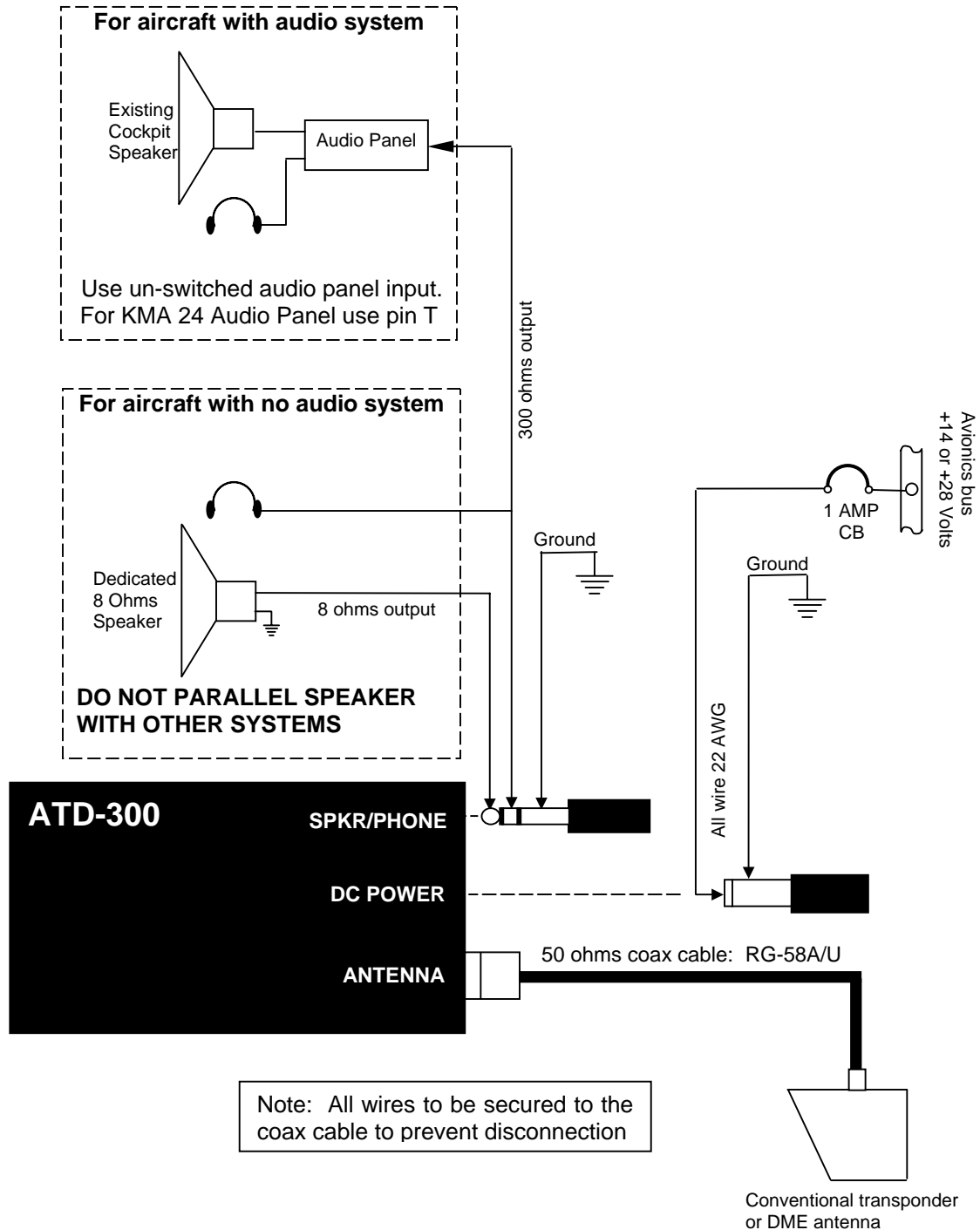

Fig. 6



## 8.0 Specifications

Frequency:	1090 MHz
MTL	-60dBm
Transponder Types	Mode A/C/S
Decoding Altitude Range:	-1200 to 30, 700 feet
Max. Range:	5nm
Range Accuracy:	20% error with external antenna
Host Transponder MTL:	-25dBm
Maximum Signal Input:	+30dBm pulse
Antenna Impedance:	50 Ohms
Audio Output Power:	2 Watts @ 8 Ohms (adjustable)
Speaker Output Impedance:	8 Ohms
Phone Output Impedance:	300 Ohms
Message Repetition Rate:	Every 20 Seconds
Voltmeter Accuracy:	1%
Supply Current:	0.18 amps @ 14VDC 0.09 amps @ 28VDC
Operating Temperature:	-20 deg C to +55 deg C
Operating Altitude:	-1000 feet to 25,000 feet MSL
Enclosure Type:	Black extruded aluminum box
Unit Weight:	10 Ounces
Unit Dimensions	2.75" W x 0.75" H x 5.0" D
Installation Depth:	6.5 inches
DO-160D Tested	Sec. 4, 5, 6, 7, 8, 16, 18, 19

## 9.0 Troubleshooting

There are no serviceable components in this product. The test equipment needed to test is very specialized and it is not commonly found in avionics shop. If you encounter difficulties please check the following suggestions:

- 1) If no power, check that the cigarette lighter jack is providing power by looking at the red LED on the power cable plug. It should be on whenever there is power. If not try another cigarette lighter jack.
- 2) If no voice output, verify that the VOICE switch is not in the MUTE position. Plug a miniature plug headphone on the back of the unit and turn the unit on. If message "*Traffic-Watch On*" is not heard adjust the VOL control on the bottom side of the unit, clockwise rotation increases volume. Try setting intercom to ISOLATE.
- 3) If the unit gets too hot to the touch the internal timing may be affected and it may not decode properly all traffic replies. Keep it away or shield the unit from sunlight.
- 4) If you suspect occasional false alarms check the following: Turn off any onboard cell phone. Turn off the strobe lights. Some unshielded strobe light wiring may cause spurious emissions that may be visible on a weather lightning scope. Relocate the ATD-300 to a different location on the glare shield. An external antenna eliminates most false alarm problems created by cell phones or other onboard equipment. Keep in mind that most GA traffic will not be visible during daytime when farther than 1nm. Ground radar stations use transponder beacons on the ground (Parrots) to check for antenna azimuth and proper radar operation. When flying near one of these beacons you may get traffic warnings but no visible aircraft. The ATD-300 can easily detect traffic at lower altitude or on the ground that is beyond ground radar horizon line coverage thus not visible to ATC.
- 5) If the ATD-300 suddenly indicates **0nm +0** altitude it is most likely interpreting the onboard transponder as traffic. Make sure the antenna is vertically oriented. Relocate the unit to a clear area on the glare shield. Pull the transponder from its tray and spray contact cleaner on the transponder contacts and on the tray contacts. Reinstall transponder. Clean transponder antenna from any carbon or oil deposits.
- 6) At times the ATD-300 will show the range and altitude of two aircraft in an alternate fashion. This is normal and helps you determine if there is more than one threat. Display priority is given to traffic at the closest indicated range.
- 7) The ATD-300 local altitude reading may not be the same as that indicated by the altimeter when the atmospheric pressure is different than 29.92". This is because transponder altitude encoders are calibrated to 29.92'.

For additional support, contact Monroy Aerospace Corp. at:  
Tel. +1-954-294-9006, FAX +1-954-344-5269, email@monroyaero.com

## LIMITED WARRANTY

All products manufactured by Monroy Aerospace Corp. are guaranteed against defective components and workmanship for a period of three years. Any product found to be defective during this period due to components or workmanship will be repaired (or replaced) to its original operating conditions.

This warranty is void if the product has been misused, altered, tampered, damaged, improperly installed or repaired by unauthorized personnel.

Any product that is to be returned for warranty or repair work shall obtain a return approval number (RAN) from the factory prior to shipping.

THE IMPLIED WARRANTY AND ALL OTHER IMPLIED WARRANTIES ARE HEREBY EXCLUDED. MONROY AEROSPACE CORP. MAKES NO OTHER WARRANTY OR REPRESENTATION OF ANY KIND WHATSOEVER EXPRESSED OR IMPLIED, AND ALL IMPLIED WARRANTIES INCLUDING ANY WARRANTY OF MERCHANTABILITY OR FITNESS FOR A PARTICULAR PURPOSE ARE HEREBY DISCLAIMED.

MONROY AEROSPACE CORP. MAXIMUM LIABILITY HEREUNDER IS LIMITED TO THE PURCHASED PRICE OF THE PRODUCT. IN NO EVENT SHALL MONROY AEROSPACE CORP. BE LIABLE FOR ANY CONSEQUENTIAL, INDIRECT, INCIDENTAL OR SPECIAL DAMAGES OF ANY NATURE ARISING FROM THE SALE OR USE OF THIS PRODUCT, WHETHER BASED IN CONTRACT, TORT, STRICT LIABILITY OR OTHERWISE.

*Monroy Aerospace Corp.*

P.O. Box 8217

Coral Springs, Florida 33075 USA

Tel. +1-954-294-9006

[www.monroyaero.com](http://www.monroyaero.com)